

UV Talk Letter

Vol.3 November 2009





UV Talk Letter

Monochromators

In this volume, we will describe the monochromator, an important part of the spectrophotometer that was explained in UV TALK LETTER Vol. 2 "The Structure of a Spectrophotometer".

Light containing various wavelengths can be broken down according to the wavelength. White light (containing many wavelengths) entering the monochromator is extracted as green (540 nm), red (650 nm), or some other monochromatic (single-wavelength) light. The operating principle can be explained by an experiment using a prism to break down sunlight, as shown in Fig. 2. A slit can be inserted in the rainbow to extract monochromatic light. Fixing the slit and rotating the prism rotates the direction of the rainbow such that the color of the extracted monochromatic light changes.

Breaking down light into its constituent wavelengths similar to a rainbow is known as "dispersion," and an element with this property is called a "dispersive element." The prism is a typical dispersive element. Another one is the diffraction grating. White light shining onto a diffraction grating reflects back in rainbow colors, as shown in Fig. 3. White light reflecting in rainbow colors from the surface of a CD is a result of the same dispersion phenomenon as the diffraction grating. In the same way as a prism, the diffraction grating can be rotated to change the color of the light extracted through the slit.

The monochromator comprises a dispersive element, an entrance slit and mirrors to create a parallel beam similar to sunlight, and an exit slit and mirrors to extract the monochromatic light.

1. Dispersive Element

The prism and diffraction grating are typical dispersive elements. Table 1 shows their respective features. Due to their superior dispersion properties, diffraction gratings are often used in modern spectrophotometers. The prism achieves dispersion due to the difference in the material refractive index according to the wavelength. However, the diffraction grating uses the difference in diffraction direction for each wavelength due to interference.

The reflective blazed diffraction grating that is commonly used in spectrophotometers is described below.

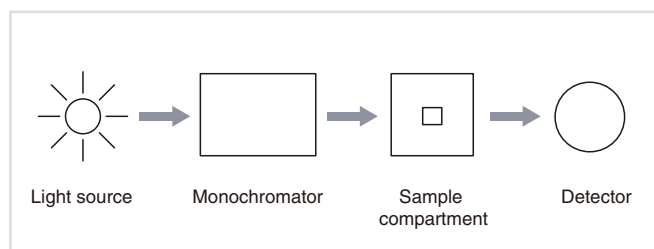

Fig.1 Construction of a Spectrophotometer

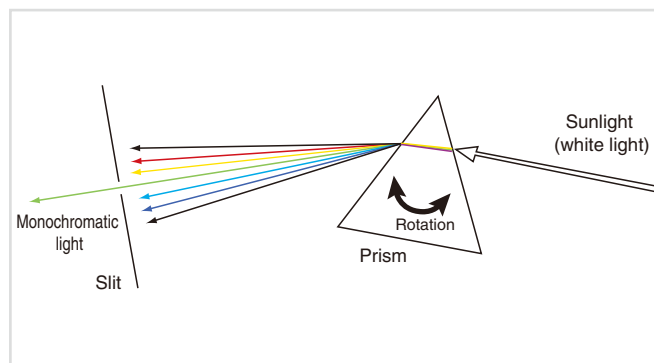

Fig.2 Prism Experiment

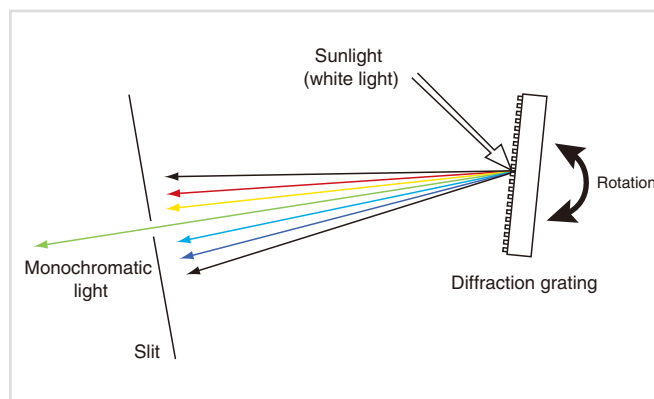

Fig.3 Using a Diffraction Grating



The diffraction gratings we study at high school are often a row of slits, as shown in Fig. 4. However, the reflective blazed diffraction grating has a sawtooth cross-section, as shown in Fig. 5. As light that passed through an adequately fine slit is diffracted, light reflected from an adequately fine sawtooth surface is also diffracted. There are 500 to 2000 serrations per millimeter.

The sawtooth face of a commercially produced diffraction grating is the replica of a master grating. A thin synthetic-resin replica is stuck onto a glass sheet and coated with aluminum. The master was traditionally produced using a machine tool, but now the surface is formed by an ion beam or using laser beam photolithography. A smooth surface reduces stray light (light at unwanted wavelengths).

This is the basic expression governing diffraction gratings:

$$m\lambda = d(\sin i + \sin \theta) \dots (1)$$

Where, d is the groove (serration) spacing, i is the angle of incidence, θ is the diffraction angle (positive if the incident light and diffracted light are on the same side of the normal to the diffraction grating surface, negative if they are on opposite sides of the normal), λ is the wavelength, and m is the order (see Fig. 6). This means that when d, m, and i are fixed, light of wavelength λ is diffracted in direction θ .

Expression (1) indicates the presence of higher-order light. If d, i, and λ are fixed in expression (1), a different value of m results in a different value of θ . This indicates that light of wavelength λ diffracts in multiple angles θ , as shown in Fig. 7. These light directions are named using a combination of the m value and the + or - sign, such as +1st-order light or -1st-order light. Incidentally, the light when m=0 is known as zero-order light, for which the diffraction angle θ is equal to the angle of incidence i. This is reflected as white light, equivalent to normal specular reflection.

The various light orders of a diffraction grating result in dispersion of the energy and a reduction in light utilization efficiency. However, the diffracted light energy from a diffraction grating with a fine sawtooth profile is concentrated in the direction of the specular reflection, as shown in Fig. 8. This wavelength is known as the "blaze wavelength." The diffraction grating in a spectrophotometer is normally used near the blaze wavelength. However, multiple diffraction gratings can be used separately to increase the efficiency over a wide range of wavelength.

A different way of viewing the phenomenon of higher-order light is to say that, if d, i, and θ are fixed in expression (1), a different value of m results in a different λ . This indicates that light of multiple wavelengths θ diffracts in diffraction angles λ , as shown in Fig. 9. Therefore, a higher-order light cutout filter (short-wavelength cutout filter) is positioned after the monochromator exit slit to extract light at a specific wavelength (normally ± 1 st-order light).

	Prism		Reflective Diffraction Grating	
Dispersion Principle	Exploits differences in the material refractive index according to the wavelength.		Exploits diffraction from a reflective surface with a regular grating structure.	
Light Utilization Efficiency	High (Generally has high efficiency despite light losses from boundary reflection and absorption during transmission through the material. A single prism covers the range from 185 to 2500 nm.)	✓	Low (Light with the same wavelength is dispersed in several directions as higher-order light. High efficiency near the blaze wavelength.)	
Wavelength Dependency of Dispersion	Variable. High for UV; low for visible to NIR light.		High and approximately constant.	✓
Temperature Dependency of Dispersion	High (Effects of temperature on refractive index.)		Low (Deformation due to temperature.)	✓
Higher-Order Light	None	✓	Yes (Requires higher-order light cutout filter.)	
Stray Light	Low	✓	High (Dispersion due to higher-order light and surface roughness. Modern diffraction gratings achieve comparatively low stray light.)	
Polarization	Low	✓	High	

Table 1 Comparison of Prism and Grating (✓ : advantageous for spectrophotometer)

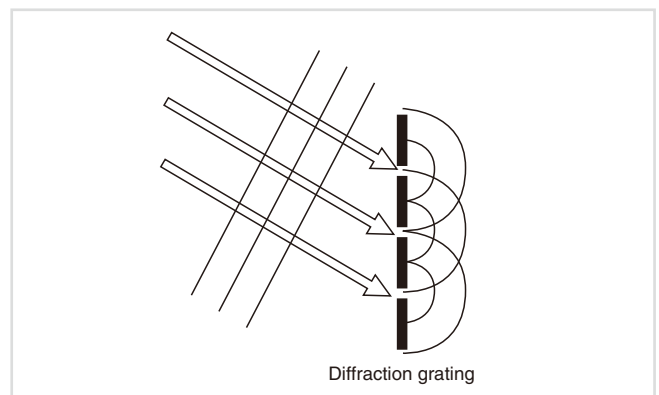

Fig.4 Diffraction Grating with Row of Slits

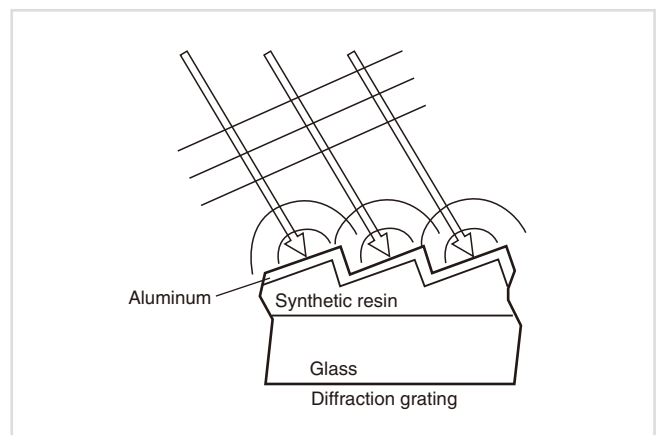

Fig.5 Reflective Blazed Diffraction Grating

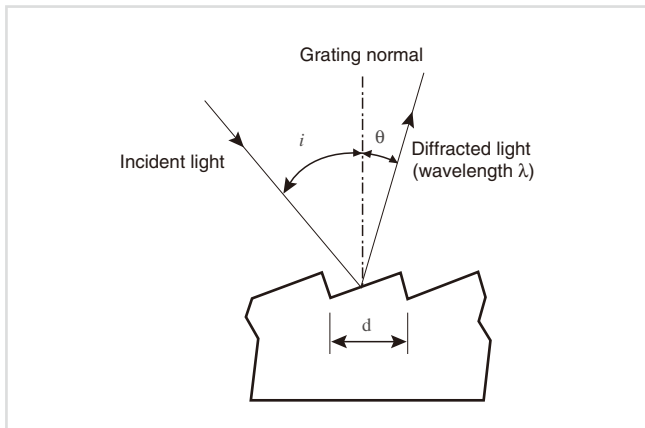

Fig.6 Basic Expression Governing Diffraction Gratings

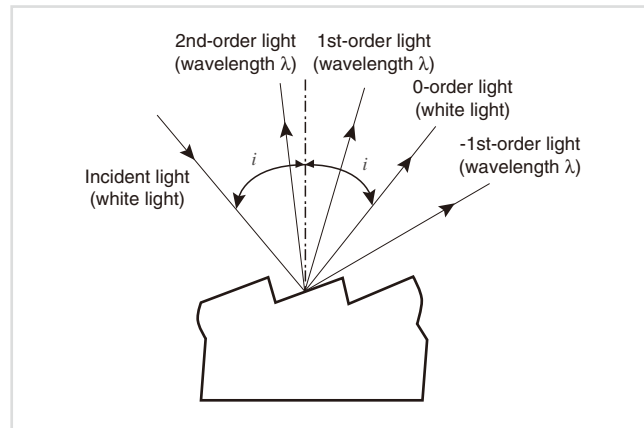

Fig.7 Higher-Order Light

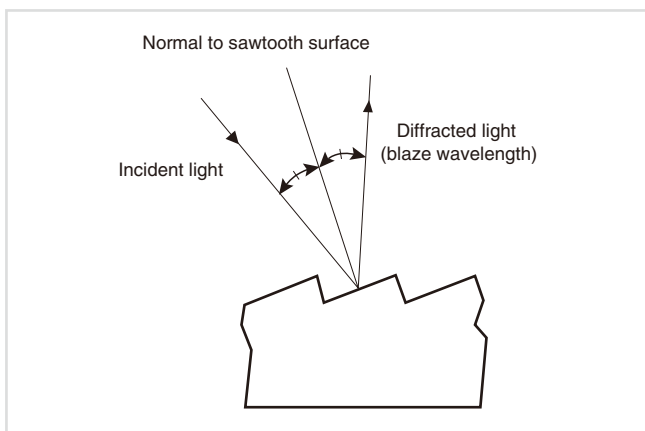

Fig.8 Blaze Wavelength

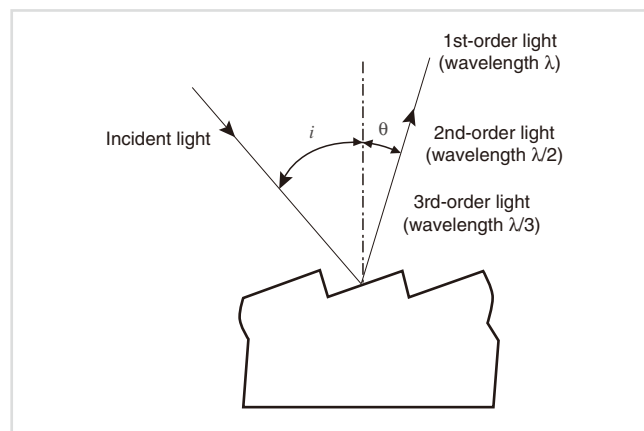

Fig.9 Higher-Order Light (2)

2. Mountings (Aligning Elements)

The basic elements of a monochromator are (1) entrance slit, (2) collimating mirror (to form a parallel beam after the slit), (3) diffraction grating (dispersive element), (4) camera mirror (focuses light from the dispersive element onto the exit slit), and (5) exit slit (see Fig. 10). In Fig. 2 and Fig. 3 a simple exit slit can extract the required wavelength, as the light beam incident on the dispersive element is narrow. A camera mirror is required in an actual monochromator, however, as light is incident over the entire surface of the dispersive element. This involves refocusing the image of the (1) entrance slit at the position of (5) exit slit at the wavelength to be extracted. The other wavelengths either miss (4) camera mirror or focus at some position away from (5) exit slit. Typical mountings used in spectrophotometers are the Littrow mount, Czerny-Turner mount, and concave mounts such as the Seya-Namioka mount. As shown in Fig. 11, the Littrow mount comprises a single spherical mirror or off-axis parabolic mirror that acts as the collimating mirror and camera mirror. The Czerny-Turner mount uses two symmetrically arranged spherical mirrors as the collimating mirror and camera mirror, as shown in Fig. 10. A concave mount uses a curved diffraction grating that offers both dispersion and focusing functions to simplify the construction, as shown in Fig. 12. This mount is used to reduce the number of mirrors where extreme resolution is not required.

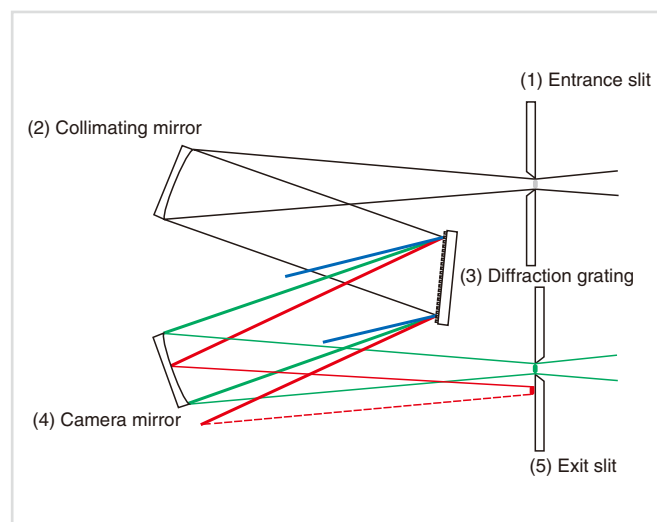

Fig.10 Basic Elements of a Monochromator (Czerny-Turner Grating Monochromator)

3. Resolution

We described above how a monochromator acts to product monochromatic (single-wavelength) light from white light. However, while it is called single-wavelength light, it covers a certain range of wavelengths. For example, 540 nm light may extend from 539.5 to 540.5 nm. Consequently, when this light is used for measurements, information for the range from 539.5 to 540.5 nm is mixed together. This light is called "1 nm-bandwidth light" and this monochromator is said to have 1 nm resolution. The smaller the wavelength band, the better the resolution. Fig. 13 shows how the resolution and bandwidth are defined as the peak width at half maximum (PWHM).

Once the monochromator elements and their positions are fixed, the resolution is determined by the slit width. As the light disperses as a rainbow, increasing the exit slit width reduces the resolution. A wider entrance slit results in a larger image at the exit slit position, such that the image for the wavelengths adjacent to the target wavelength enters the exit slit and reduces the resolution.

A diffraction grating has its own inherent resolution, which is determined by the diffraction principle according to the number of gratings. The improvement in monochromator resolution possible by reducing the slit width is limited due to this diffraction grating resolution, the aberration of the overall optical system, and mirror imperfections.

The monochromator slit width used in a spectrophotometer is expressed not as the slit width dimension but as the value of the resolution achieved. Setting the slit width to 1 nm, sets the monochromator resolution to 1 nm, such that 1 nm-bandwidth light shines onto the sample.

For measurements by spectrophotometer, the optimal resolution is determined by the spectral shape of the sample. A slightly larger slit width increases the light intensity reaching the detector and reduces the data noise but results in poorer resolution. Originally sharp spectral peaks broaden as shown in Fig. 14. A narrow slit width achieves a spectrum shape closer to the original spectrum. For example, if the original spectrum has a peak waveform, setting the slit width to between 1/8 and 1/10 the PWHM results in a measured peak with at least 99% the original height.¹⁾

However, if the aim is not to determine the spectrum shape itself but to conduct concentration measurements using a calibration curve, these measurements are possible if the waveform is slightly imperfect. If noise detracts from measurement accuracy with the slit width set at 1/8 the PWHM, a slightly larger slit width may be appropriate. Shimadzu spectrophotometers normally achieve satisfactory resolution and light intensity for concentration measurements on solutions when the slit width is set between 1 nm and 2 nm. The slit width is normally set to 5 nm or above for measurements of solids using the integrating sphere. A larger slit width is set to reduce noise due to light losses in the integrating sphere, as high resolution is often not required when measuring solids.

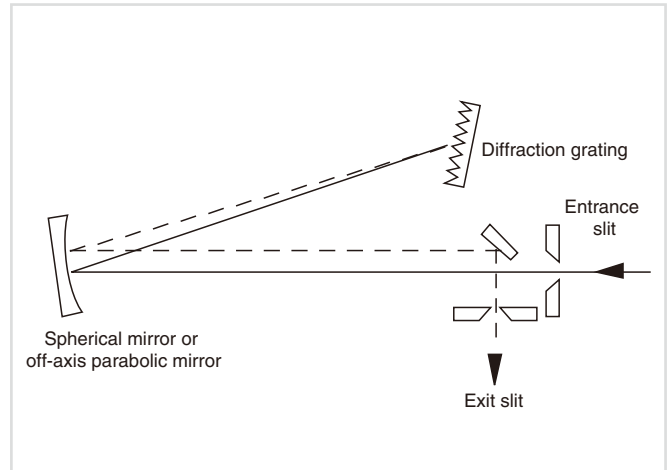

Fig.11 Littrow Grating Monochromator

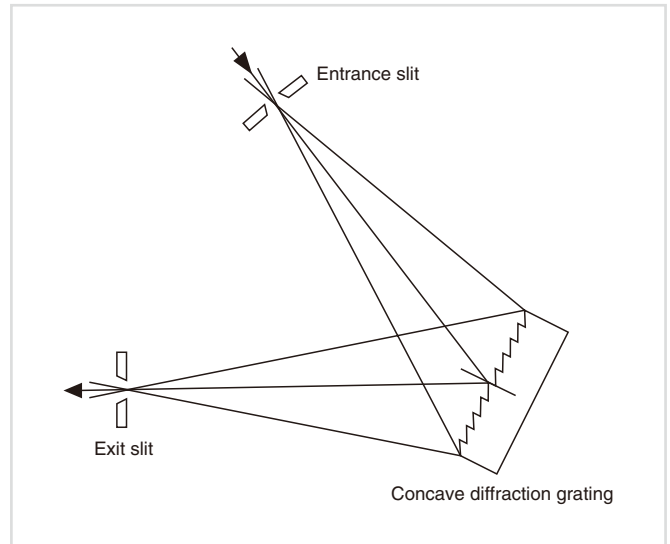

Fig.12 Concave Grating Monochromator

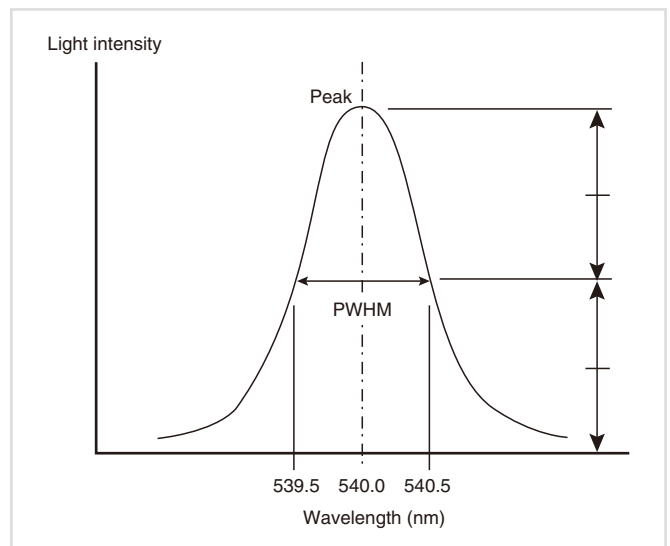

Fig.13 1 nm-Bandwidth Light

4. Conclusions

We explained the monochromator, which extracts monochromatic light from polychromatic light. However, when monochromatic light enters the monochromator, it exits only in a direction specific to the diffraction grating. This property can be used to determine the wavelength of the monochromatic light. This is the method normally used when the monochromator is used alone. A monochromator is incorporated into fluorescence spectrophotometers and emission spectrometers to determine the wavelength of fluorescence lines or emission lines emitted from the sample. In this case, the monochromator is located between the sample compartment and detector. The detector will be described in the next UV TALK LETTER. We hope you will continue to enjoy reading the UV TALK LETTERS.

1) Shimadzu Absorption Spectrometry Course Text, "Principle, Construction, and Applications of Spectrophotometers" (Shimadzu Corporation)

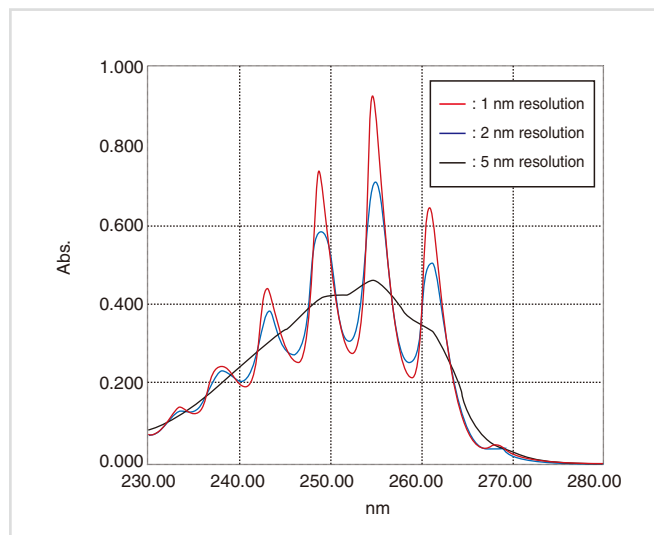

Fig.14 Difference in Spectrum Shapes Due to Resolution
(Analysis of Ethanol Solution of Benzene)

Spectroscopy Business Unit, Analytical & Measuring Instruments Division
Toshio Kimura

Color measurement

1. Color

When a person views an object, light from a light source that is reflected from the object (or passes through the object) enters the eye and is collected by several types of photoreceptor cells in the retina. The proportion of light collected by these cells is sent to the brain and sensed as color. In practice, the simple proportion of light collected undergoes various processing as it passes along the nerves before being recognized by the person as color.

Color measurements are a method of expressing the colors sensed by humans as values.

Color measurements are related to illumination, spectral characteristics of the object, and the spectral sensitivity characteristics of the human eye. As the spectral distribution of the illumination and the spectral sensitivity characteristics (color-matching function) of the eye are defined in the JIS standards, a color value can be calculated if the spectral reflection of the object is known. (If the light passes through the object, the spectral transmittance can be used for the calculation. However, the spectral reflectance is used in the explanations below.) To explain in more detail, in the JIS standard, the spectral distribution of the illumination and color-matching function are calculated using multiple conditions. We are familiar with a change in color when the illumination is changed. Therefore, a different coefficient is set for each illumination spectral distribution. In addition, the color also changes according to the viewfield (viewing angle), due to the relationship with the sensitivity distribution characteristics of the retina. Consequently, the JIS standard sets different color-matching functions according to the viewfield.

Color measurements require a wavelength range from 380 nm to 780 nm, which is equivalent to the wavelengths that can be sensed by the human eye. Color measurements can be made by calculations based on spectral reflectance measurements by a UV-VIS spectrophotometer across this wavelength range. Color measurement software is available for simple color measurements.

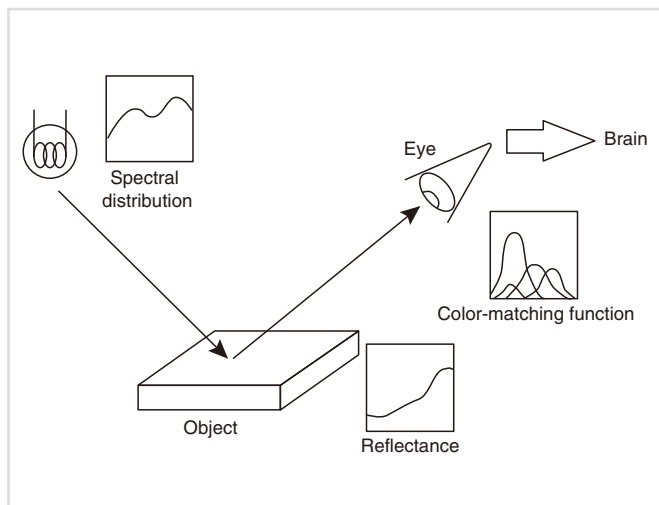

Fig.1 What is Color Measurement?

2. Color Measurement

To perform color measurements with a UV-VIS spectrophotometer, first measure the spectral reflectance of the object. Calculations based on the spectral distribution of the illumination, the spectral reflectance obtained for the object, and the color-matching function express the color as a numeric value. Illumination spectral distributions and color-matching function values are stored in the color measurement software to obtain color measurement values when the spectral reflectance spectrum is measured.

The XYZ tristimulus values are the basis of color measurement. JIS Z 8722 "Methods of color measurement -- Reflecting and transmitting objects" calculates the XYZ tristimulus values using the expressions below.

$$\left. \begin{aligned}
 X &= K \sum_{380}^{780} S(\lambda) \bar{x}(\lambda) R(\lambda) \Delta\lambda \\
 Y &= K \sum_{380}^{780} S(\lambda) \bar{y}(\lambda) R(\lambda) \Delta\lambda \\
 Z &= K \sum_{380}^{780} S(\lambda) \bar{z}(\lambda) R(\lambda) \Delta\lambda \\
 K &= \frac{100}{\sum_{380}^{780} S(\lambda) \bar{y}(\lambda) \Delta\lambda}
 \end{aligned} \right\} \dots\dots\dots(1)$$

Where,
 S(λ): illumination spectral distribution value at wavelength λ
 x̄(λ), ȳ(λ), z̄(λ): color-matching function values in the XYZ color system
 R(λ): sample spectral reflectance
 Δλ: wavelength interval for calculation

In addition to the XYZ tristimulus values, several other color specification systems for expressing colors are known. The color measurement software can perform calculations in the following color specification systems: XYZ tristimulus values, xy color coordinates, Hunter Lab color scale, L*a*b* color system, L*u*v* color system, and U*V*W* color system. Values for color specification systems other than the XYZ tristimulus value system are calculated from the XYZ tristimulus values.

3. Color Difference

A color specification system is a method of expressing colors as numerical values, while color difference expresses the difference between colors. Calculations to numerically express color difference values use the Uniform Color Space (UCS) color specification system that is closer to the human visual sense. The L*a*b* color system is a typical UCS color specification system. L* represents the brightness, and a* and b* represent the hue and saturation. JIS Z 8729 "Colour specification -- CIELAB and CIELUV color spaces" shows the method of calculation in the L*a*b* color system.

The color difference is calculated using the L*a*b* value for each object (sample) color. The color difference ΔE*ab in the L*a*b* color system is determined using expression (2) in JIS Z 8730 "Color specification -- Color differences of object colors."

$$\Delta E^*_{ab} = \sqrt{(\Delta L^*)^2 + (\Delta a^*)^2 + (\Delta b^*)^2} \dots\dots\dots(2)$$

If the color coordinates of two objects (samples) are denoted $L^*a^*b^*_1$ and $L^*a^*b^*_2$, it can be seen from the expressions

$$\Delta L^* = L^*_1 - L^*_2$$

$$\Delta a^* = a^*_1 - a^*_2$$

$$\Delta b^* = b^*_1 - b^*_2$$

that the color difference is equivalent to the distance between two points in the $L^*a^*b^*$ color space. The greater the difference between the two colors, the larger the color difference value.

In addition to displaying the color system and the color difference in the color specification system, the color measurement software can perform other calculations including whiteness index, yellowness, major wavelengths, and excitation purity.

4. Setting Color Measurement Conditions

Several conditions are set for the color measurement calculations. These conditions are the illumination (light source) and viewfield (viewing angle).

Settings for the illumination are required, as the color varies according to the illumination on the sample. Illumination settings include A, B, C, and D65. In the JIS standards, these are called standard illuminant and supplementary standard illuminant. The spectral distribution is different for each illumination. For example, standard illuminant A is used to calculate object colors under illumination by an incandescent light bulb. Standard illuminant D65 is used to calculate object colors in daylight including the UV light region. The color measurement software allows user-defined illumination settings to handle illumination conditions not provided as standard.

The viewfield (viewing angle) must also be set, as the color appears different when a sample is observed close-up or from a distance. For a viewfield up to 4 degrees, a 2° mean viewing angle is used for the calculations (color viewed from a distance); for a viewfield over 4 degrees, a 10° mean viewing angle is used for the calculations (color viewed close-up). The color-matching functions differ for a 2° mean viewing angle and a 10° mean viewing angle.

If the parameter settings are changed while reading the spectrum, the displayed color measurement values in the list change immediately.

Fig. 2 shows the calculation parameter setting screen.

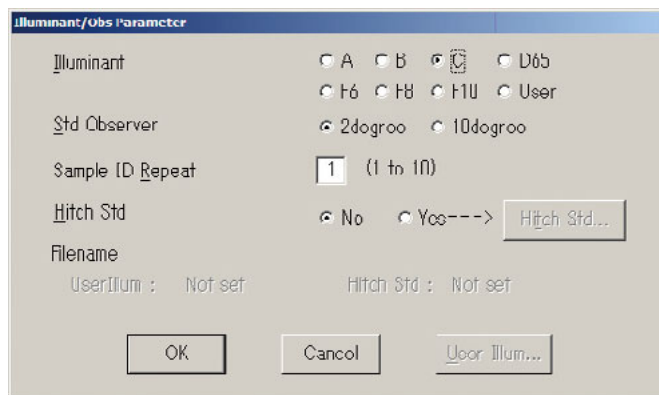

Fig.2 Calculation Parameter Settings

The color measurement software can simultaneously display up to six calculation items. If the calculation items are changed while reading the spectrum, the displayed color measurement values change immediately.

Fig. 3 shows the screen to select the calculation items.

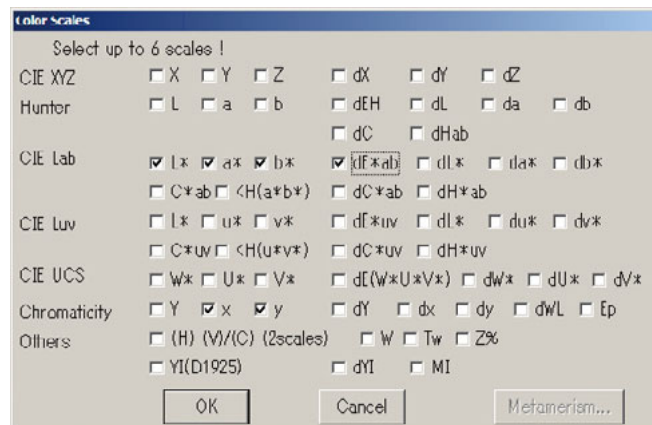

Fig.3 Selecting the Calculation Items

5. Spectral Reflectance Measurements

The measurement parameters must be set before measuring the spectral reflectance.

To set the measurement parameters, set the photometric value (transmittance / reflectance), wavelength range (normally set from 380 nm to 780 nm), scan rate, slit width, and sampling pitch.

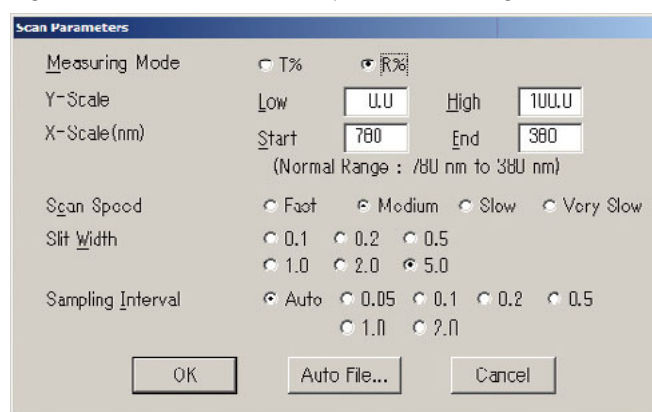

Fig.4 Measurement Parameter Settings

An integrating sphere is often used to measure the spectral reflectance of an object. Fig. 5 shows the photograph of an integrating sphere with a sample in position. The spectral reflectance can be measured by installing the sample as shown in the photograph.

Fig. 6 and Fig. 7 show examples of spectral reflectance measurements using an integrating sphere. Fig. 6 shows the spectral reflectance measurement results for pink paper, and Fig. 7 shows the spectral reflectance measurement results for light-blue paper. Barium sulfate was used as the standard white plate for reference.

The visible range encompasses the blue color system (400 nm to 500 nm), green color system (500 nm to 600 nm), and red color system (600 nm to 700 nm). The graphs show that the pink paper reflects more in the red color system, while the light-blue paper reflects more in the blue color system.

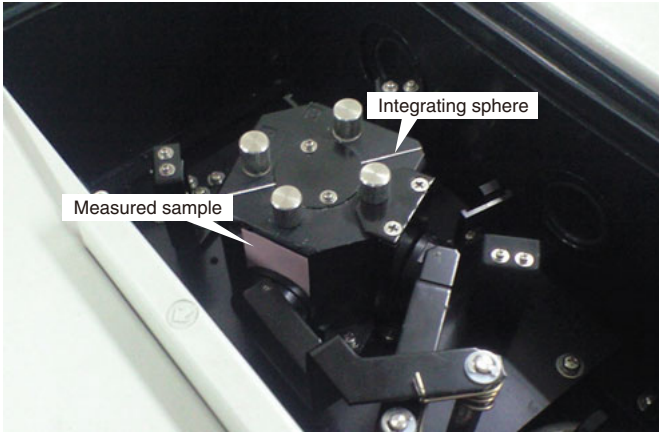

Fig.5 Sample Positioned on Integrating Sphere

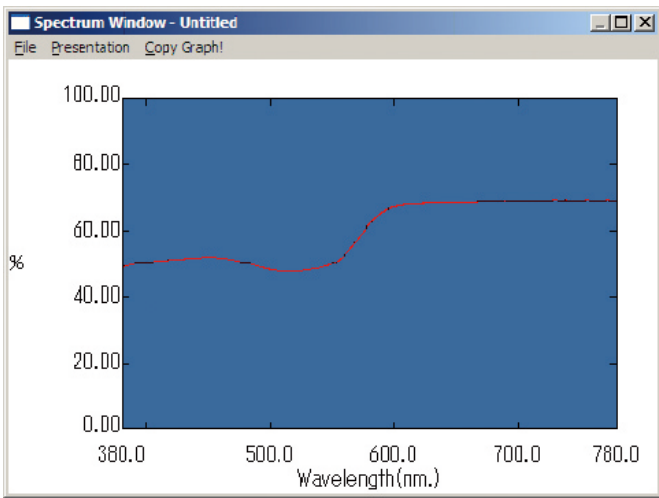

Fig. 6 Measured Reflectance Spectrum for Pink Paper

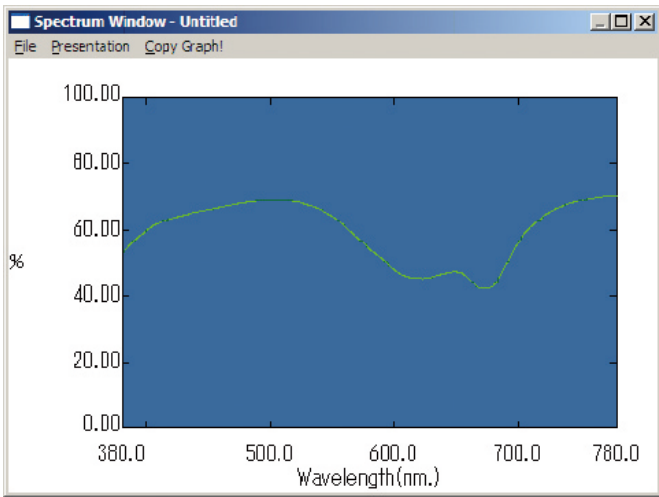

Fig. 7 Measured Reflectance Spectrum for Light-Blue Paper

The color measurement values calculated from the spectral reflectance are displayed as a list. Naturally, calculations can also be performed on existing spectral reflectance data. Fig. 8 shows a display of the color measurement results. The calculation conditions were illumination C and 2-degree viewfield. The first row shows the color measurement results for the pink paper ($L^*=79.45$, $a^*=11.50$, $b^*=4.48$ [red frame in diagram]). The second row shows the color measurement results for the light-blue paper ($L^*= 81.71$, $a^*=-11.56$, $b^*=-5.95$ [blue frame in diagram]).

The color measurement software can also display the color difference. The color difference is calculated based on a reference sample (the sample with ID set to 0 [green frame in diagram]). In this case, the pink paper is set as the reference sample. The color difference between the pink paper and the light-blue paper is $\Delta E^*ab = 25.41$ [black frame in diagram].

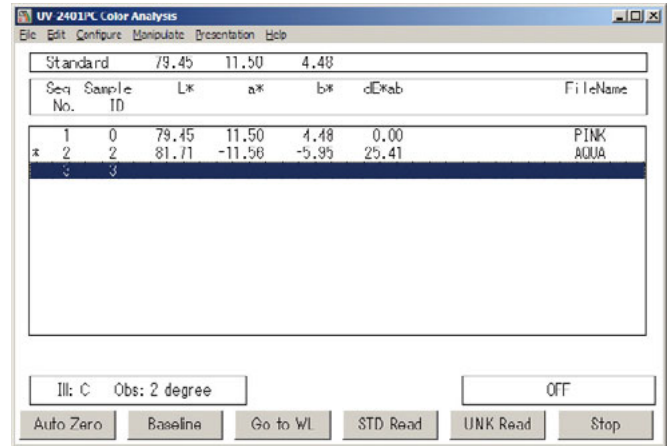

Fig. 8 Display of Color Measurement Results

A chart display function shows the color measurement results in a clearly visible form. The color measurement results shown in the list display can be displayed as a chart. Fig. 9 shows the chart display of the color measurement results in Fig. 8. In the L^* graph at the left, the color becomes brighter as the data point moves upward, and the color becomes darker as the data point moves downward. In the a^*b^* graph at the right, the color becomes duller as the data point moves toward the center, and the color becomes more brilliant as the data point moves toward the perimeter. In addition, the radius vector angle from the center represents the hue. For example, the top-right direction from the center of the circle represents red colors.

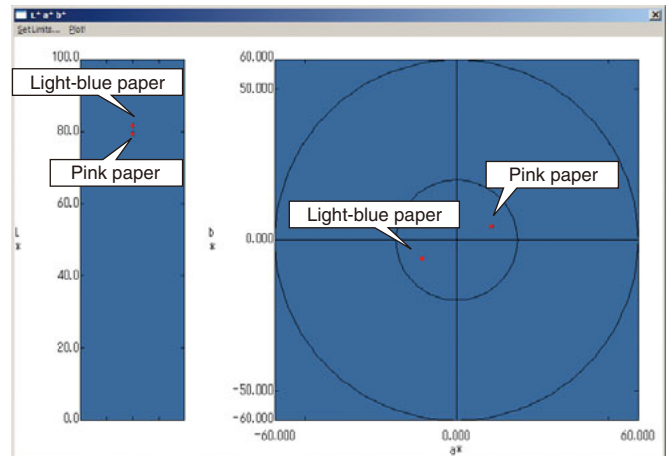

Fig. 9 Chart Display

6. Data Correction

A standard white plate is used for the spectral reflectance measurements required to measure the object reflection color (color measurement by reflection). The standard white plates used include barium sulfate, magnesium oxide, alumina, and fluororesin. However, as these have high reflectance across the overall measurement wavelength range, adequate color comparison is possible if the same instrument is used.

However, as a standard reflectance plate does not form a perfect diffusing surface and does not offer 100% reflectance, the spectral reflectance values measured for samples are relative values. Extremely high-accuracy measurements are required to make a comparison of the measured results obtained by different instruments. Making highly accurate measurements requires correction of the spectral reflectance to the spectral ratio reflectance with respect to a perfect reflection diffusing surface. The white plate correction function is used for this correction. By entering the spectral reflectance for the corrected standard white plate, the measured spectral reflectance is corrected to be equivalent to the measured results for a perfect reflection diffusing surface.

Conversely, correction for the thickness is applied to measurements of the transmission color of an object (color measurement by transmission). A change in sample thickness results in a change in spectral transmittance that results in different color measurement results. Thickness correction is a function to determine the transmission color for the required thickness (target thickness).

Thickness correction by entering the actual measured thickness, the target thickness for which the color is to be determined, and the surface reflectance (or surface reflectance calculated from the refractive index) permits comparison of transmission colors between samples of different thickness.

Thickness correction makes the following calculations. (See Fig. 10.)

- 1) Determine the internal transmittance, excluding the measured surface reflectance of the sample.
- 2) Apply thickness correction to the internal transmittance and subsequently add the surface reflectance.

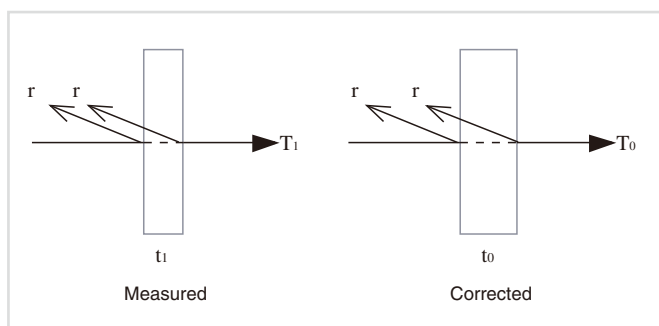

Fig. 10 Concept of Thickness Correction

Expression (3) is used for actual thickness correction calculations to determine the transmittance T_0 at each wavelength.

$$\left. \begin{aligned} T_1' &= \frac{T_1}{\left(1 - \frac{r}{100}\right)^2} \\ T_0 &= 100 \times \left(\frac{T_1'}{100}\right)^{\frac{t_0}{t_1}} \times \left(1 - \frac{r}{100}\right)^2 \end{aligned} \right\} \dots\dots\dots(3)$$

Where,

- T_1 : measured transmittance (%)
- T_1' : internal transmittance (%) with respect to measured transmittance (%)
- r : sample surface reflectance
- t_1 : measured sample thickness [measured thickness] (mm)
- t_0 : sample thickness to determine the transmittance for [target thickness] (mm)
- T_0 : calculated transmittance (%)

Instead of entering the surface reflectance, the value calculated from the refractive index n using following expression can be entered:

$$r(\%) = 100 \times \left(\frac{n-1}{n+1}\right)^2$$

This yields 4% surface reflectance for glass with refractive index 1.5.

Color calculations are performed after determining thickness-corrected transmittance values at each wavelength.

7. Summary

JIS standards define calculation methods and coefficients for color measurements in detail. If the spectral reflectance is known, the calculations can be performed using spreadsheet software. However, different coefficients are required for different illumination and viewfields, which requires a huge number of inputs.

The color measurement software can be used to select the conditions and measure the spectral reflectance to simplify color measurements.

Tokyo Applications Development Center,
Analytical Applications Department,
Analytical & Measuring Instruments Division
Hirokazu Abo



How should I measure the spectrum for a solution?



Two types of spectrophotometer construction are available. One is the single-beam type with a single light beam in the sample compartment. The other is the double-beam type that has two light beams in the sample compartment. (See UV TALK LETTER Vol. 1 Q&A.) The measurement procedure using each type is explained below.

Single-beam type

1. Put the solution in a cell and put the cell in the cell holder.
2. Conduct baseline correction.
3. Remove the cell and discard the solution. Rinse the cell twice with the measured sample solution to be measured. Fill the cell with sample solution and mount it in the cell holder.
4. Conduct the measurement. Repeat steps 3 and 4 for the number of samples.

Double-beam type

1. Put the solution into two cells. Mount the cells in the reference (R) and sample (S) cell holders.
2. Conduct baseline correction.
3. Remove the sample (S) cell and discard the solution. Rinse the cell twice with the measured sample solution to be measured. Fill the cell with sample solution and mount it in the cell holder.
Leave the cell at the reference (R) side unchanged.
4. Conduct the measurement. Repeat steps 3 and 4 for the number of samples.

NEW PRODUCTS

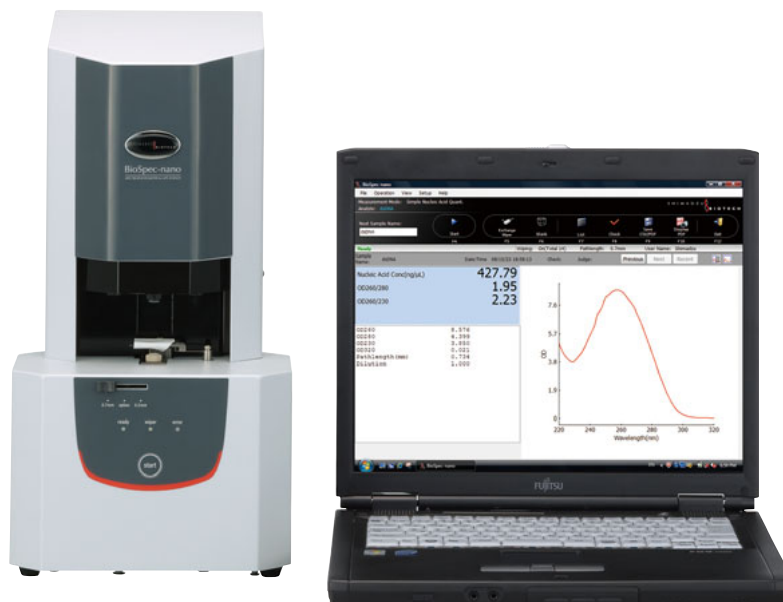

BioSpec-nano

Shimadzu Spectrophotometer for Life Sciences

Easy-to-use system offers quick and easy nucleic acid quantitation.

This is a dedicated spectrophotometer for checking the concentration and purity of nucleic acid samples. It analyzes 1 to 2 μL trace samples of nucleic acids. Simply drop the sample onto the window with a pipette and press the [Start] button on the instrument or click the [Start] button on the software screen to start automatic light path setting, measurement, and sample wiping after measurement. It is not necessary to make vertical arm adjustments or wipe the window with a cloth.

Dedicated software simplifies operation. Just click buttons on the toolbar to conduct basic operations including measurement, report printing, and exporting data.

Founded in 1875, Shimadzu Corporation, a leader in the development of advanced technologies, has a distinguished history of innovation built on the foundation of contributing to society through science and technology. We maintain a global network of sales, service, technical support and applications centers on six continents, and have established long-term relationships with a host of highly trained distributors located in over 100 countries. For information about Shimadzu, and to contact your local office, please visit our Web site at www.shimadzu.com



JQA-0376



SHIMADZU CORPORATION. International Marketing Division

3. Kanda-Nishikicho 1-chome, Chiyoda-ku, Tokyo 101-8448, Japan

Phone: 81(3)3219-5641 Fax: 81(3)3219-5710

URL <http://www.shimadzu.com>

The contents of this brochure are subject to change without notice.